

FITNESS	PISTON	LEST	CHARGEUR	R-PRO	INOX	STREET WORKOUT
STATION COMBO	PARCOURS SANTÉ	COMBATTANT	PLATEAU NINJA	FIGHT CLUB	SENIOR	MOBILIER

VÉLO ELLIPTIQUE



Visionner



TRAVAILLER LE CARDIO ET LES CUISSES !

Debout sur l'appareil, placer les mains sur les poignées et courir tout en ramenant les poignées vers soi alternativement.

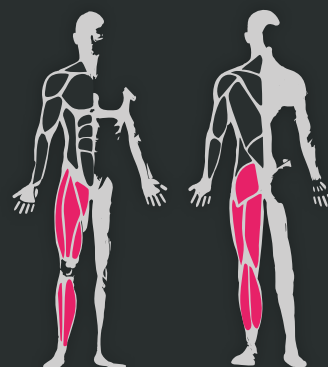

DIMENSIONS

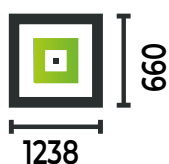

**COACHING
PERSONNALISÉ**



10 GARANTIE*
ANS



LES COMPOSANTS

- 1** Poignées antidérapantes collées.
- 2** Support pour déposer votre boisson et votre smartphone.
- 3** Roulements à billes inox, étanches et graissés à vie.
- 4** Plan d'entraînement en inox, riveté sur la potence et traduit en 4 langues pour 4 profils sportifs.

- 5** Articulations avec rattrapage d'axe testé à plus de 100 000 cycles.
Zone de liaison pivot conforme aux exigences de la norme pour éviter les coincements de doigts.
- 6** Cale-pieds en acier zingué thermolaqué.
- 7** Fixation sur platine standard.
Cache scellement en acier.

Quelle finition de sol pour une installation conforme ?

Béton, enrobé et stabilisé



Terreau naturel



Sol engazoné



Copeaux de bois*



Gravier*



Sable*



Sol souple*



Dalle amortissante*



Gazon synthétique*



* Selon la norme EN 16630.

ZONE D'IMPACT

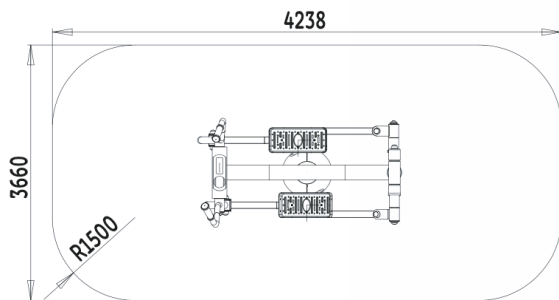

FONDATION SCELLEMENT

Tabouret d'ancrage

