

FITNESS	PISTON	LEST	CHARGEUR	R-PRO	INOX	STREET WORKOUT
STATION COMBO	PARCOURS SANTÉ	COMBATTANT	PLATEAU NINJA	FIGHT CLUB	SENIOR	MOBILIER

TRIPLE POUTRE

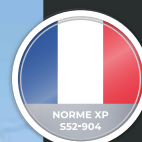

UN PLATEAU CONNECTÉ !

Avec les agrès du plateau Ninja, améliorez votre agilité, votre vitesse et votre force et connectez vous à l'application gratuite Freetness pour y comparer et y enregistrer vos propres records !

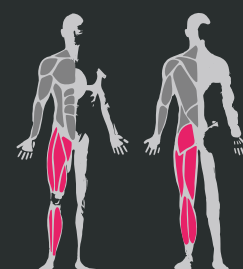

DIMENSIONS

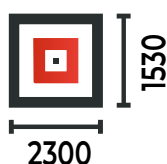

COACHING
PERSONNALISÉ



10 GARANTIE*
ANS



05 24 84 77 27



CONTACT@FREETNESS.FR



WWW.FREETNESS.FR

LE CONCEPT NINJA

ÉLÉMENT ISSU D'UN PARCOURS COMPLET PERMETTANT DE PARTICIPER À UNE COMPÉTITION EN LIGNE (VOIR CI-DESSOUS) !

UN CONCEPT COUPLÉ À L'APPLICATION FREETNESS

À PARTIR DE NOTRE APPLICATION MOBILE INSTALLÉE GRATUITEMENT SUR SON TÉLÉPHONE, L'UTILISATEUR DÉCOUVRE LE CONCEPT NINJA FREETNESS.

UNE FOIS LES RÈGLES DU JEU CONSULTÉES, IL PEUT ALORS FILMER SA PERFORMANCE ET ENGISTRER SON RECORD.

SA VIDÉO SERA ENSUITE VÉRIFIÉE PAR NOS SERVICES, PUIS PUBLIÉE ET VISIBLE DE TOUS LES AUTRES NINJAS DE FRANCE !

**INSTALLEZ UN PARCOURS NINJA COMPLET !**

OÙ QU'IL SOIT INSTALLÉ, LE PLATEAU SE COMPOSE DES MÊMES ÉLÉMENTS, INSTALLÉS À L'EXACTE MÊME DISTANCE LES UNS DES AUTRES.

AINSI, LES PERFORMANCES DES NINJAS PEUVENT ÊTRE COMPARÉES MÊME S'ILS NE PRATIQUENT PAS AU MÊME ENDROIT !





LES COMPOSANTS

1 Structure en acier galvanisé thermolaqué.

Sur quel type de sol pouvons-nous poser l'équipement ? *

Béton, enrobé et stabilisé



Terreau naturel



Sol engazoné



Copeaux de bois*



Gravier*



Sable*



Sol souple*



Dalle amortissante*



Gazon synthétique*



* Selon la norme EN 16630.

ZONE D'IMPACT

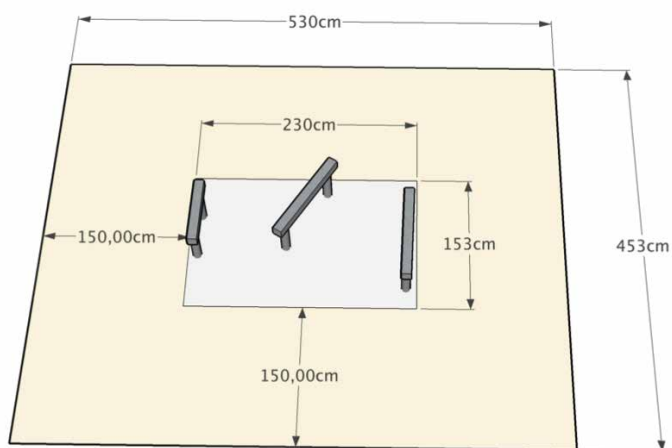

1



FONDATION SCÈLLEMENT

Direct noyé dans un plot de béton

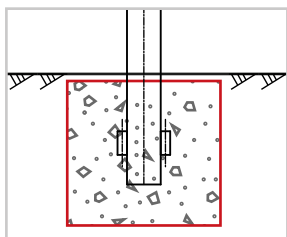

FONDATION CHEVILLAGE

Sur poteaux platines (en option)

