

FITNESS	PISTON	LEST	CHARGEUR	R-PRO	<b>INOX</b>	STREET WORKOUT
STATION COMBO	PARCOURS SANTÉ	COMBATTANT	PLATEAU NINJA	FIGHT CLUB	SENIOR	MOBILIER

## RAMEUR INOX



### TRAVAILLER LE CARDIO ET SE TONIFIER !

Le rameur est un agrès très accessible qui permet de se tonifier l'ensemble du corps en douceur.

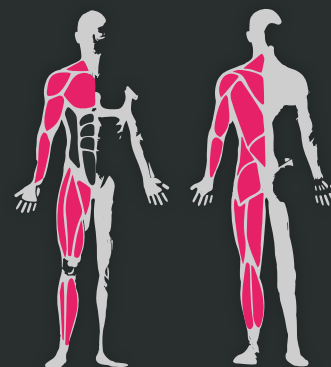

#### DIMENSIONS

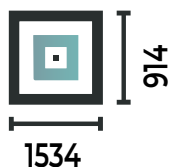

COACHING  
PERSONNALISÉ

DISPONIBLE SUR  
Google play



Télécharger dans  
l'App Store



**10** GARANTIE\*  
ANS



05 24 84 77 27



CONTACT@FREETNESS.FR



WWW.FREETNESS.FR



## LES COMPOSANTS

**1** Appareil en inox 316 !  
Poignées antidérapantes collées.

**2** Plan d'entraînement sur la potence, traduit en 4 langues pour 4 profils sportifs.

**3** Siège en PEHD (Polyéthylène Haute Densité).

**4** Cache en acier.

Quelle finition de sol pour une installation conforme ?

Béton, enrobé et stabilisé

Terreau naturel

Sol engazoné

Copeaux de bois\*

Gravier\*

Sable\*

Sol souple\*

Dalle amortissante\*

Gazon synthétique\*

\* Selon la norme EN 16630.

### ZONE D'IMPACT

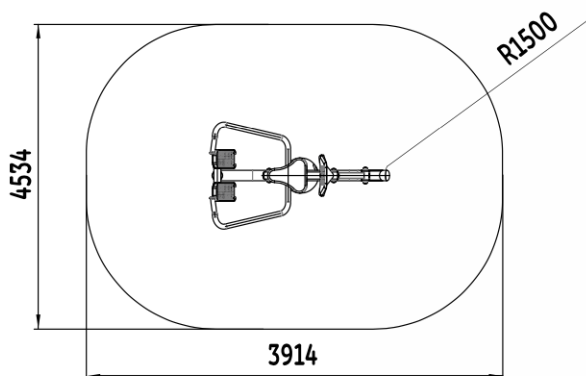

### FONDATION SCELLEMENT

Tabouret d'ancrage

